

New Energy Efficient Air Conditioning Solutions for Indian Railways



Challenges Unique to India

- **High Ambient Temperature**
- **Urban Heat Effect**
- **Voltage Fluctuations**
- **Poor Water Quality**
- **Rising Power Cost**



Energy cost of Indian Railways



**Non Traction Energy
Consumption: 2.5 Billion
units per annum**

Annual Energy Cost : Rs.1700 Cr

Energy Consumption Pattern

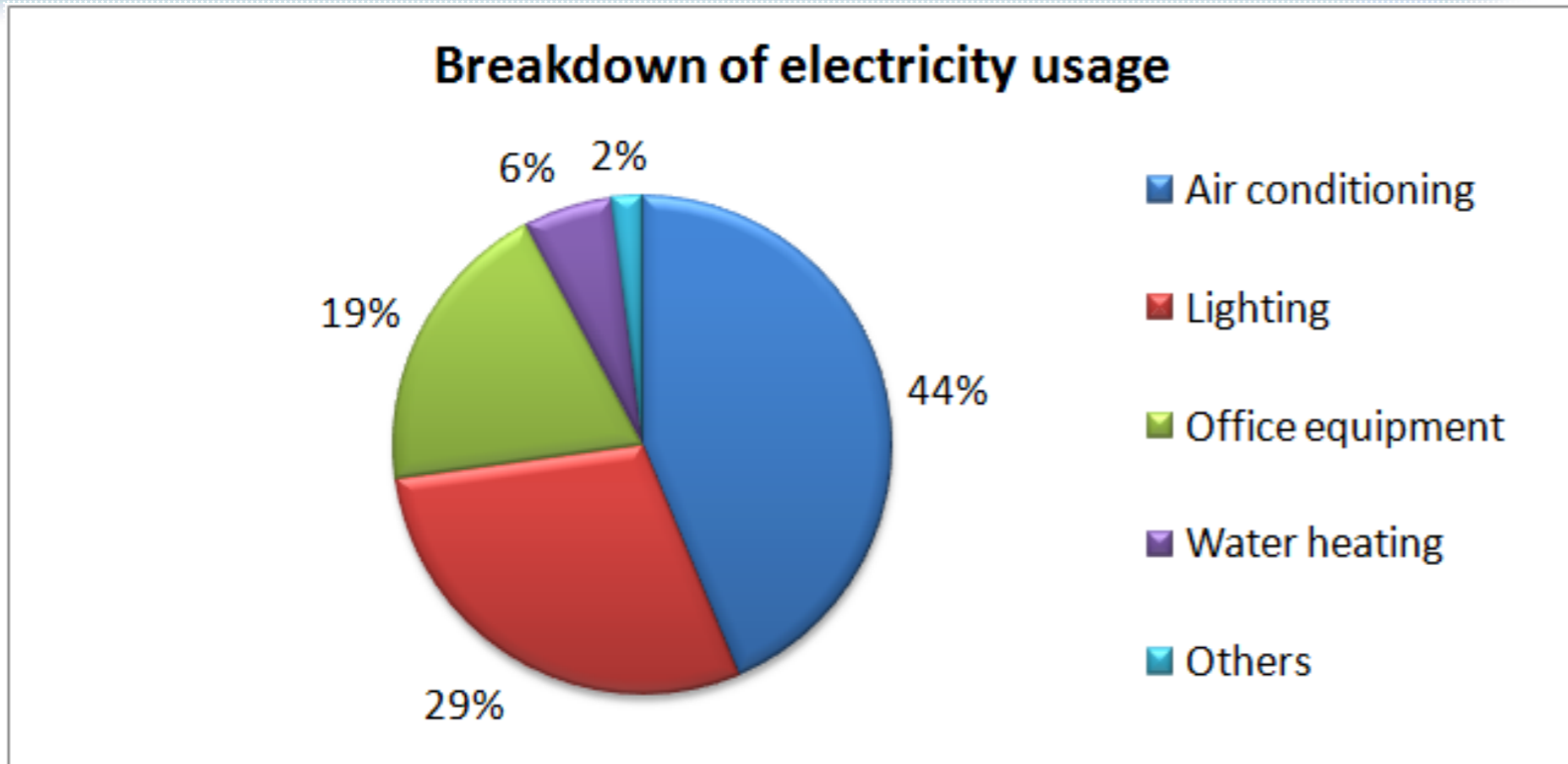

- **Air conditioning consumes around 40% energy in any Commercial Building**
- **Increasing awareness among clients for energy efficient air conditioners**



Energy Efficiency Standards for Chillers



Leading regulators for chiller efficiencies and environment protection

- ASHRAE (American Society of Heating, Refrigeration and Air conditioning Engineers)
- ECBC (Energy Conservation Building Code, Government of India)
- IGBC (Indian Green Building Council)

Ashrae 90.1.2016 (prescribes minimum efficiency standards)

◆ Water cooled screw chillers

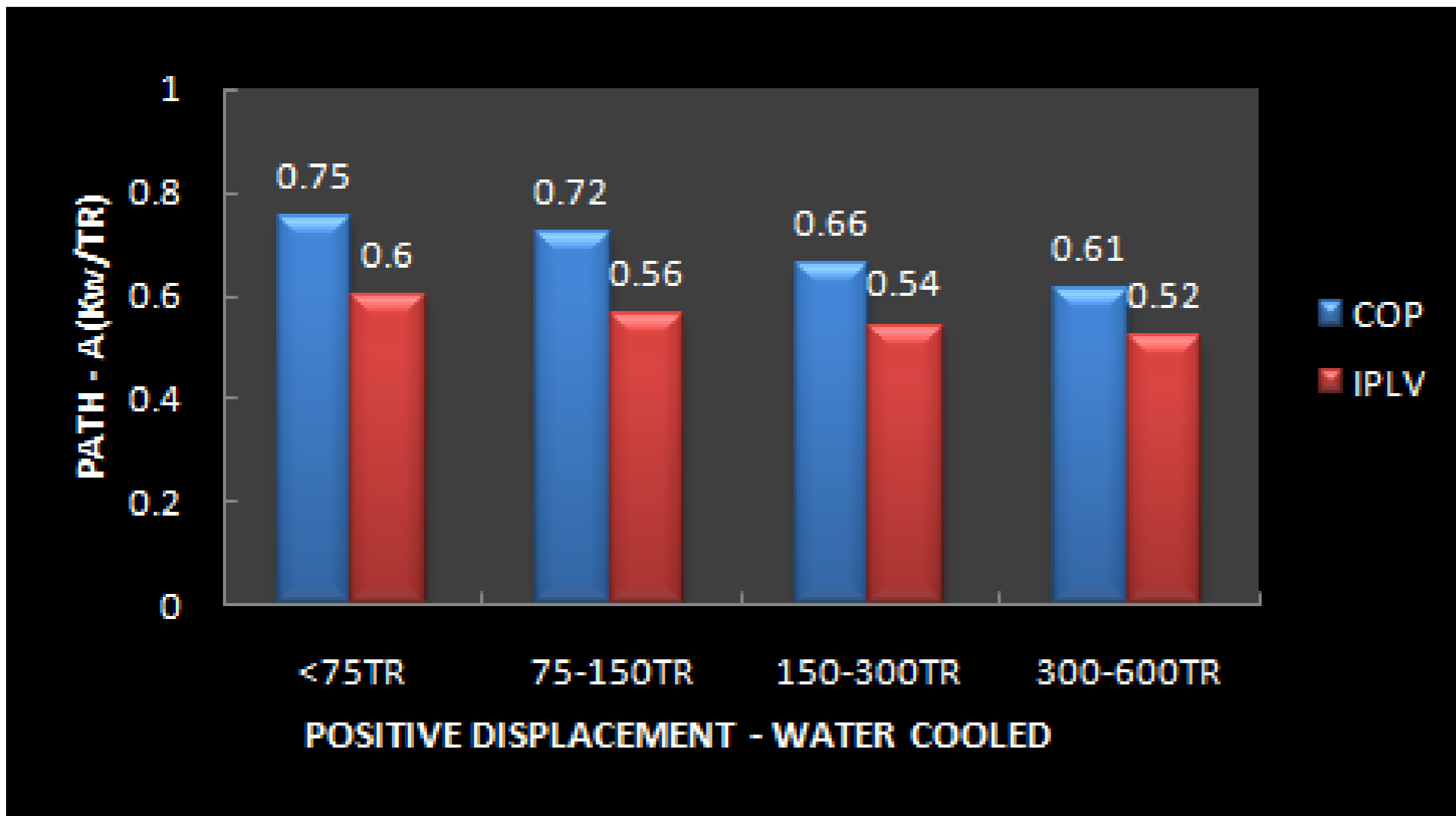

Ashrae 90.1.2016 (prescribes minimum efficiency standards)

◆ Air cooled screw chillers

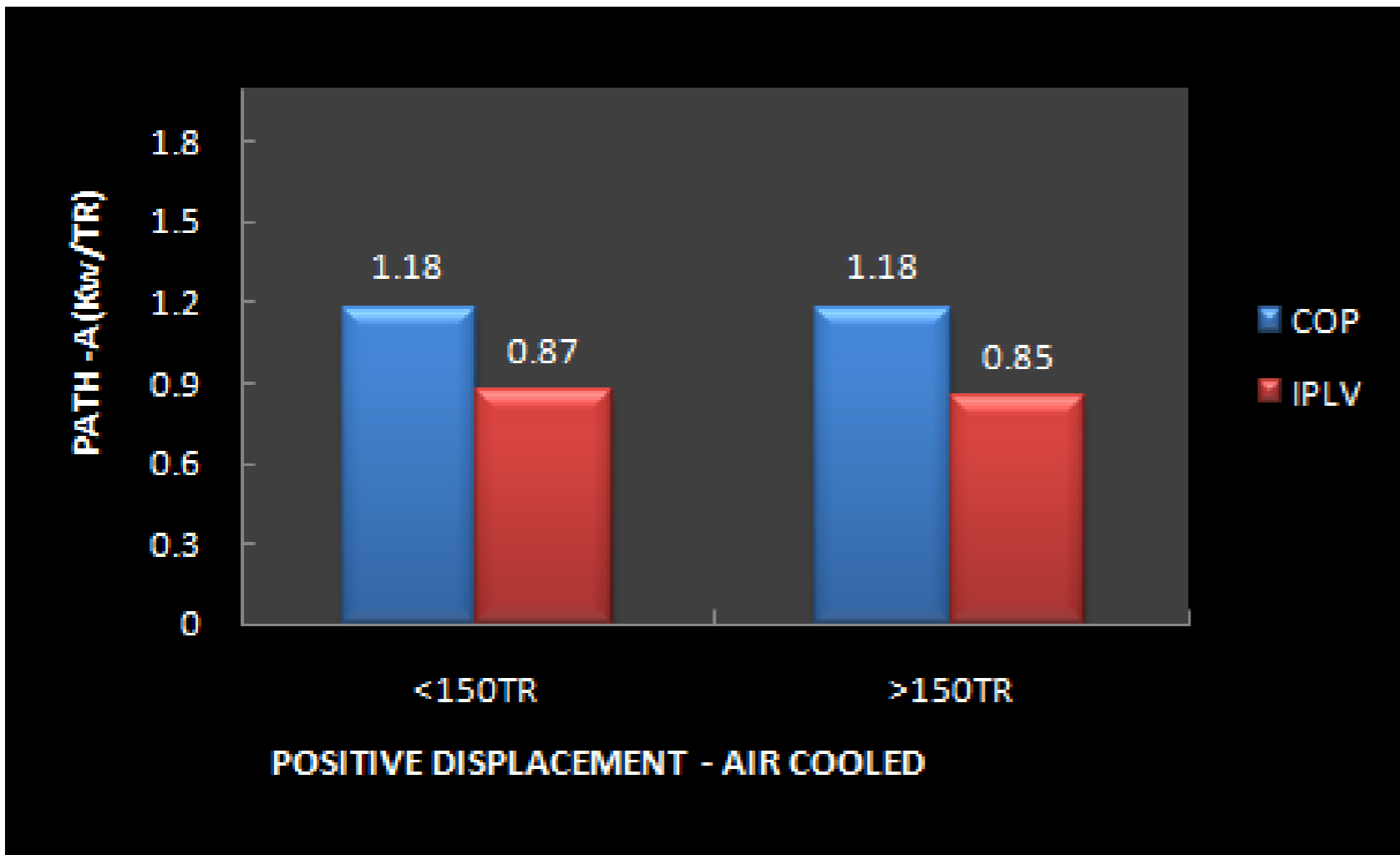

Energy Conservation Building Code – 2017 (Prescribes Minimum Efficiency)

◆ Water cooled screw chillers

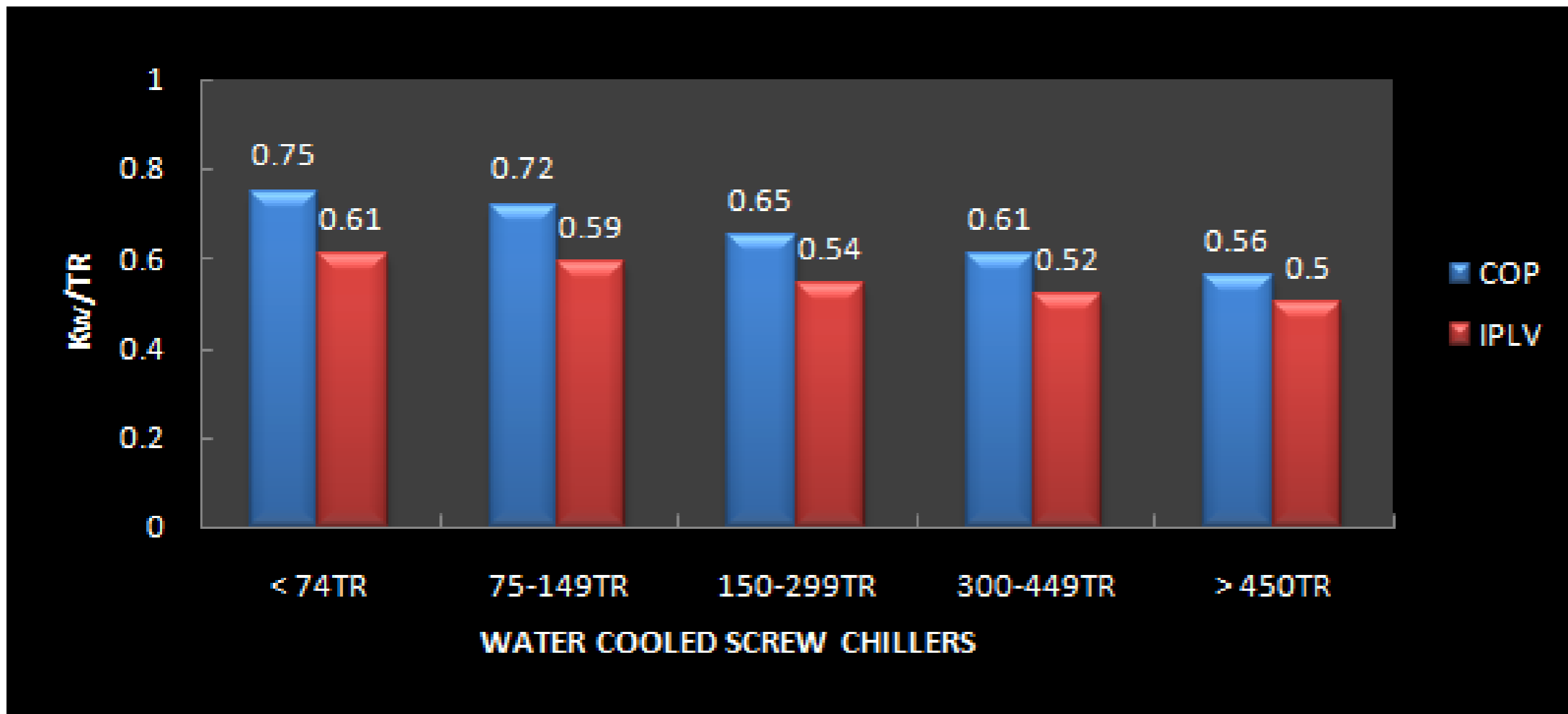

Energy Conservation Building Code – 2017 (Prescribes Minimum Efficiency)

- Air cooled screw chillers

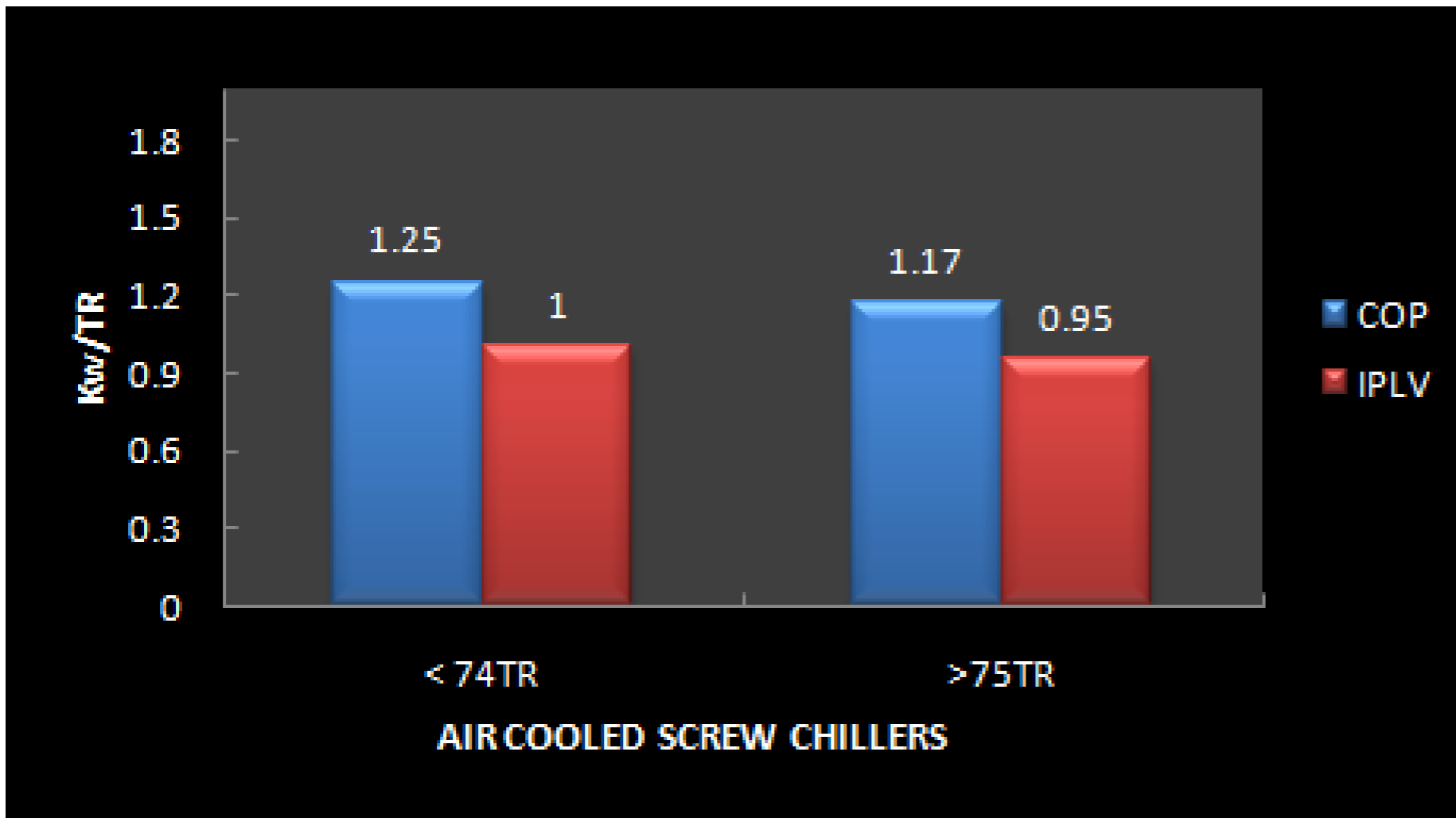

Indian Green Building Council (Prescribes efficiency and environment protection)

- **Optimise energy consumption as per Ashrae 90.1.2010**
- **Reduce Ozone Depletion and Global Warming (No chlorofluorocarbon based refrigerants)**
- **Emphasize on Greener India**



Indian Green Building Council



Indian Seasonal Energy Efficiency Ratio

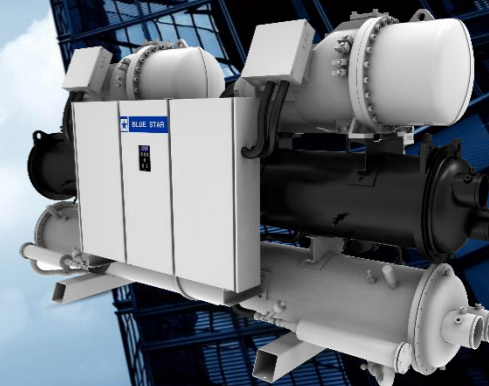

Features of New Indian Operation Norms for Chillers

ISEER performance rated at:

- Higher ambient temperature
- Average water quality
- Optimized weightage at part loads



New Indian Operation Norms for Chillers

<i>Operating parameter</i>	<i>Water Cooled</i>	<i>Air cooled</i>
<i>Chilled water leaving temperature</i>	<i>44.6 deg F</i>	<i>44.6 deg F</i>
<i>Chilled water entering temperature</i>	<i>53.6 deg F</i>	<i>53.6 deg F</i>
<i>Chilled water fouling factor</i>	<i>0.00025</i>	<i>0.00025</i>
<i>Condenser water entering temperature</i>	<i>86 deg F</i>	
<i>Condenser water leaving temperature</i>	<i>95 deg F</i>	
<i>Condenser water fouling factor</i>	<i>0.0005</i>	

New Indian Operation Norms for Chillers

<i>Capacity Loading for ISEER (%)</i>	<i>Water cooled (deg F)</i>	<i>Air cooled (deg F)</i>	<i>Loading Percentage</i>
100	86	102.2	6%
75	78.8	89.6	48%
50	73.4	78.8	36%
25	68	68	10%

Comparison of AHRI Vs Indian std

Water Cooled Screw Chillers

Capacity	Condenser Water Entering Temp (Deg F)		Performance Weightage	
	AHRI	ISEER	AHRI	ISEER
100%	85.1	86	1%	6%
75%	74.84	78.8	42%	48%
50%	64.94	73.4	45%	36%
25%	64.94	68	12%	10%

Comparison of AHRI Vs Indian std

Air Cooled Screw Chillers

Capacity	Ambient Air Temp (Deg F)		Performance Weightage	
	AHRI	ISEER	AHRI	ISEER
100%	95	102.2	1%	6%
75%	80.06	89.6	42%	48%
50%	64.94	78.8	45%	36%
25%	54.86	68	12%	10%



Introduction of Blue Star Energy Efficient Screw Chillers





Key Features

- **Efficiency exceeds Ashrae 90.1.2016 regulations**
- **Efficiency higher than ECBC 2017 guidelines**
- **Complies Green Building norms**
- **Optimized for the new Indian Operating Conditions**

Air cooled Screw Chillers



Single compressor series

Twin compressor series

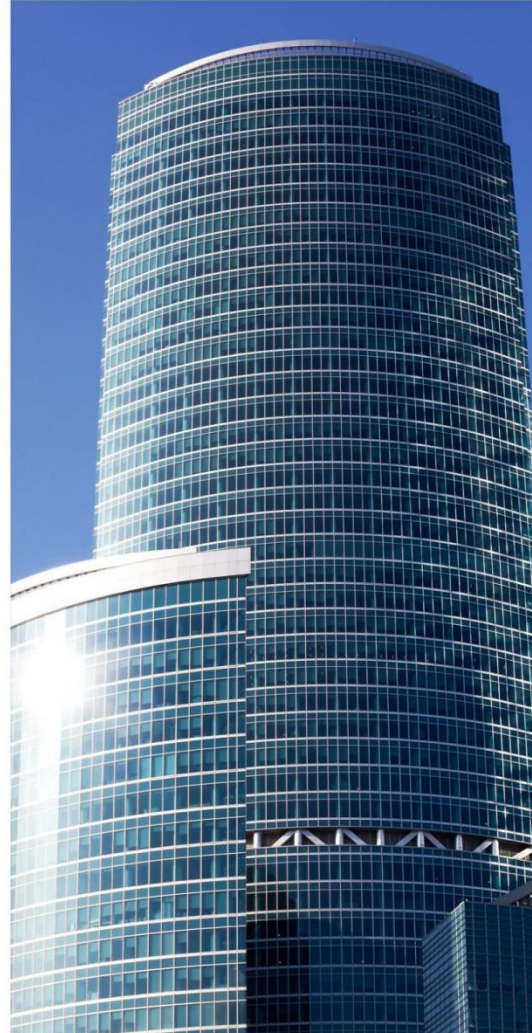

Water cooled Screw Chillers

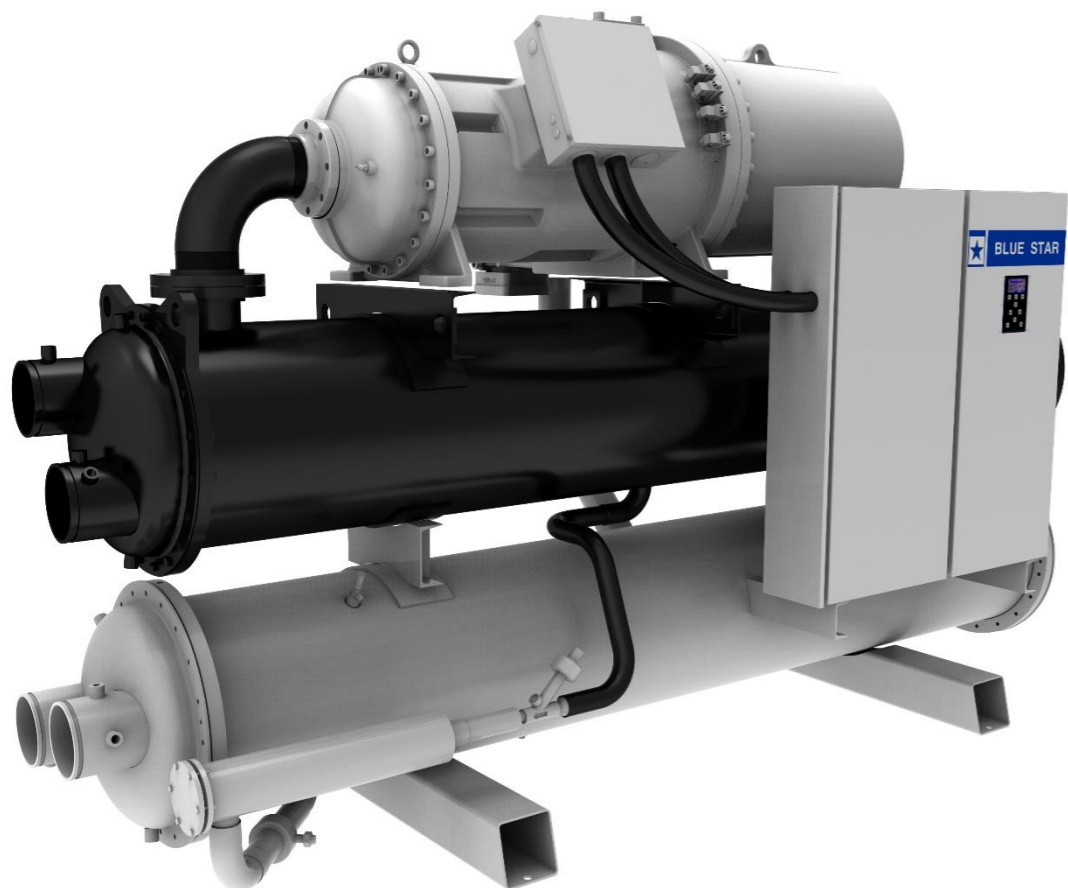

Single Compressor series

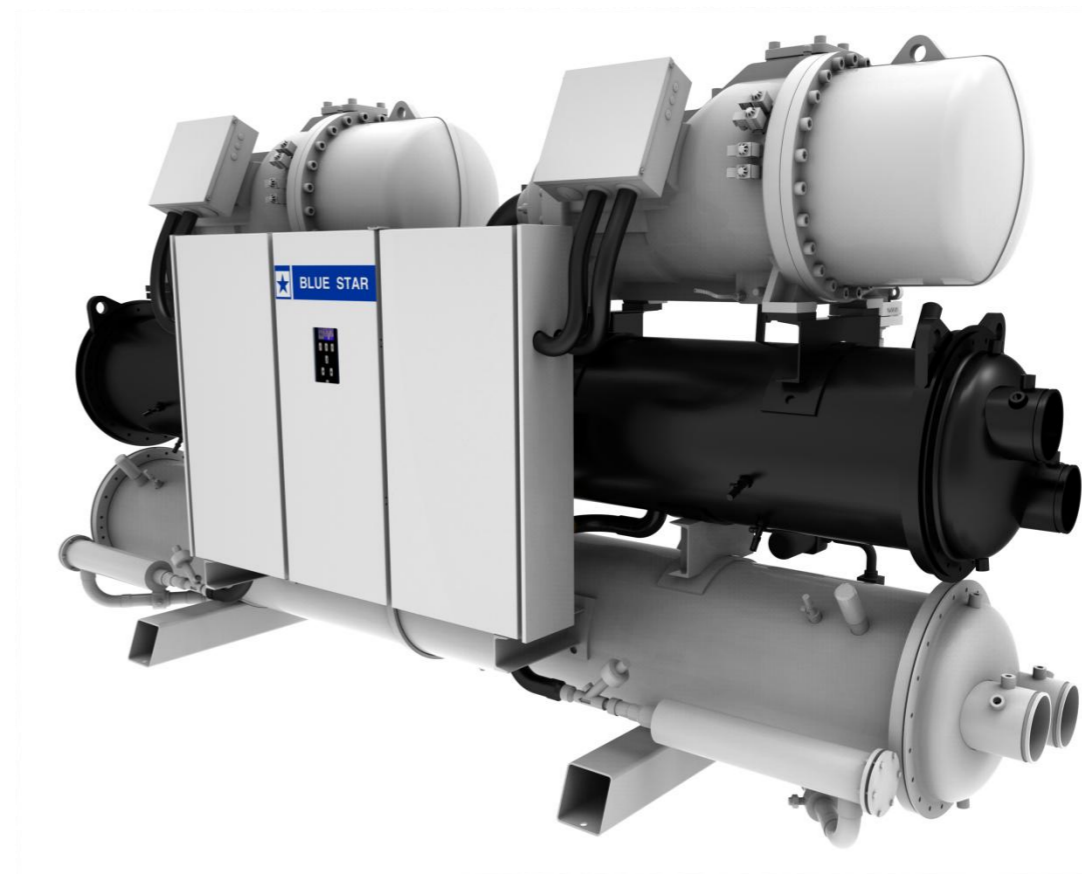

Twin Compressor series

Chiller Range



AHRI CERTIFIED
www.ahridirectory.org

Water-Cooled Chillers
AHRI Standard 550/590



Water Cooled Chiller Type

Capacity Range

Single Compressor Series

80 - 300TR

Twin Compressor Series

160 - 450TR

Air Cooled Chiller Type

Capacity Range

Single Compressor Series

100 - 200TR

Twin Compressor Series

130 - 400TR



More features of Latest Blue Star Energy Efficient Chillers



Customized to match exact requirements

- Capacity in TR
- Efficiency, both full and part loads
- Pressure drops
- Flow rates etc

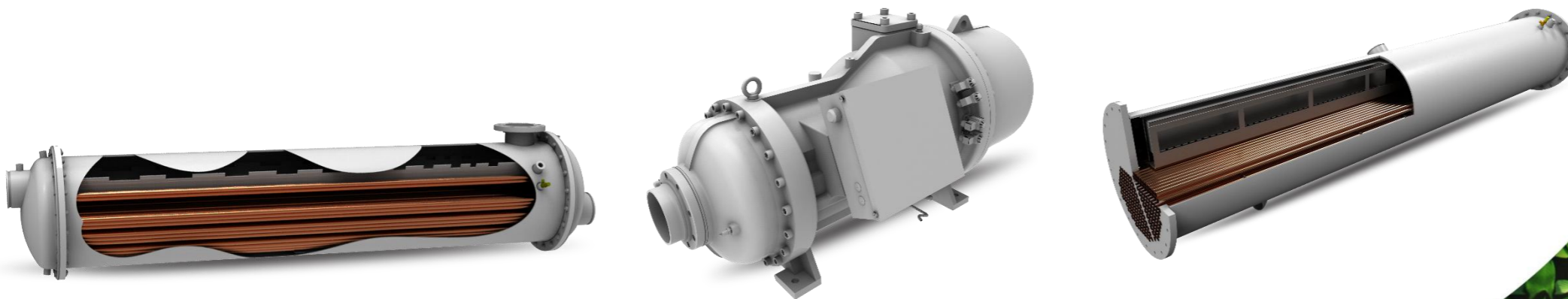

Performance validated by AHRI – Leading International testing and validating agency



AHRI CERTIFIED™
www.ahridirectory.org

Water-Cooled Chillers
AHRI Standard 550/590

AHRI CERTIFIED™
www.ahridirectory.org

Air-Cooled Chillers
AHRI Standard 550/590

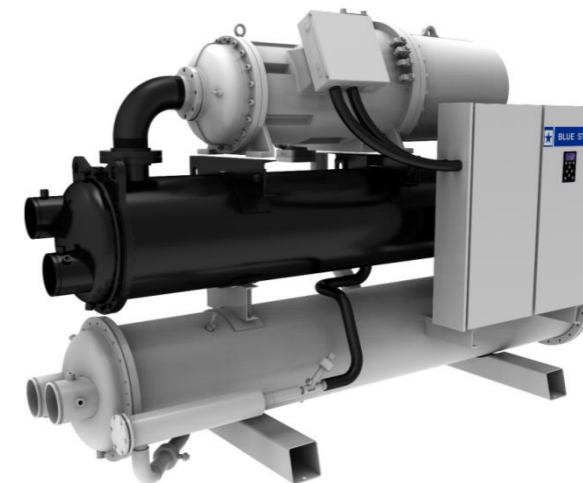

◆ **Owns Sophisticated AHRI-Certified Testing Facility (India's only test bed for both air cooled and water cooled chillers)**

Flexible Flow Rates



Heat Exchanger	Minimum - US gpm/TR
Cooler	1.0
Condenser	1.3

Ideal for Variable Pumping System



<i>Heat Exchanger</i>	<i>Maximum - US gpm/TR</i>
<i>Cooler</i>	<i>3.5</i>
<i>Condenser</i>	<i>5.0</i>

Ideal for low delta T and higher chilled water temperature applications

Lowest Pressure Drop Across Heat Exchangers



Cooler:
7ft of water column



Condenser:
12ft of water column



Lower cooler and
condenser pump
capacities

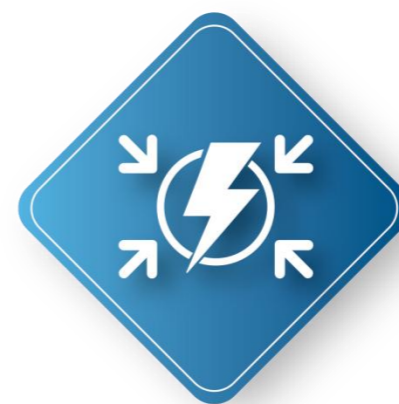

Reduced total
connected power

Optimised Starting Current

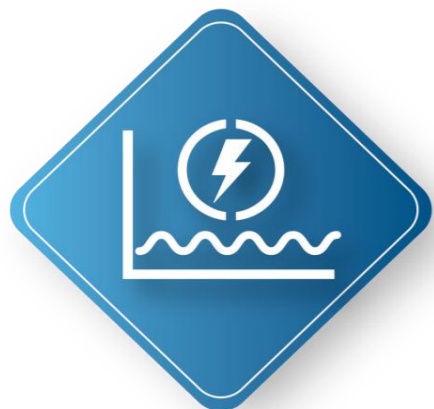

Starting current as low as 1.75 times full-load current

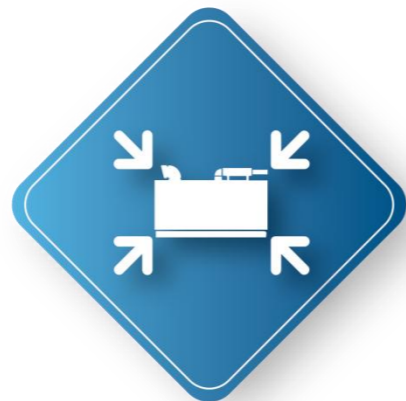

Reduction in generator capacity



Optimised electrical components



Saving in overall project cost



Advanced Controllers



BMS compatible



Trending facility for real-time performance analysis



Scheduling



Auto battery back-up



Multi-level password protection



Auto power failure reset

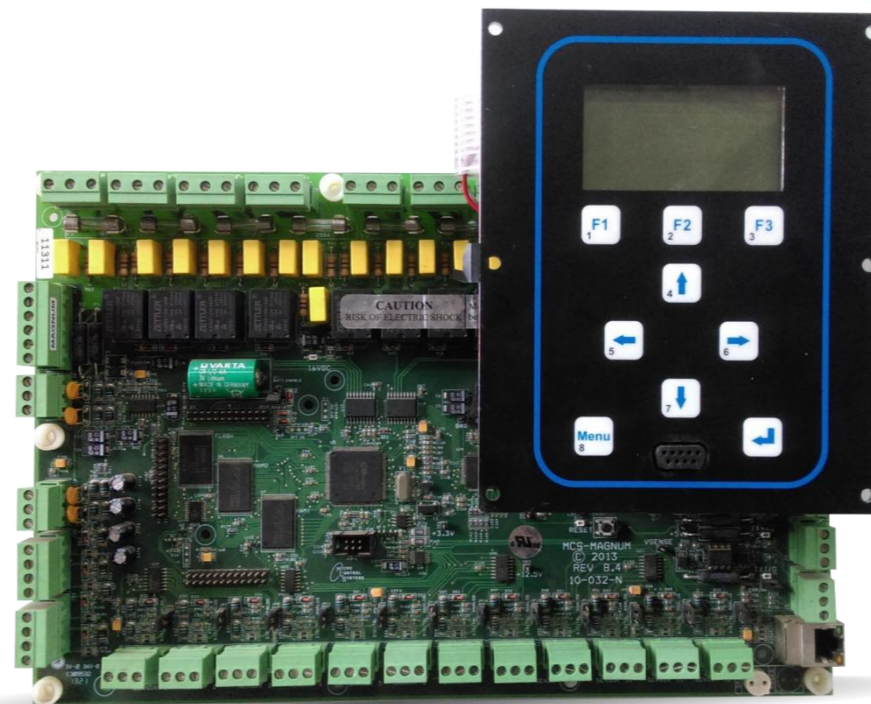

Remote Monitoring System



GPRS-based remote monitoring



Close monitoring of site



Automatic call login to service technician when fault occurs



24 x 7 automatic monitoring



Automatic notification through SMS/Email when fault occurs

Advantages:

Very quick response | Faster turnaround time | Higher uptime of system

Better service quality even in tier-2 / tier-3 towns



Advanced VRF System for Indian Railways

VRF V^{PLUS}
100% INVERTER

**100% capacity at 43°C.
Non-stop cooling even at 56°C.**





BLUE STAR

Unique Features



VRF V^{PLUS}
100% INVERTER

100% CAPACITY EVEN AT 43°C

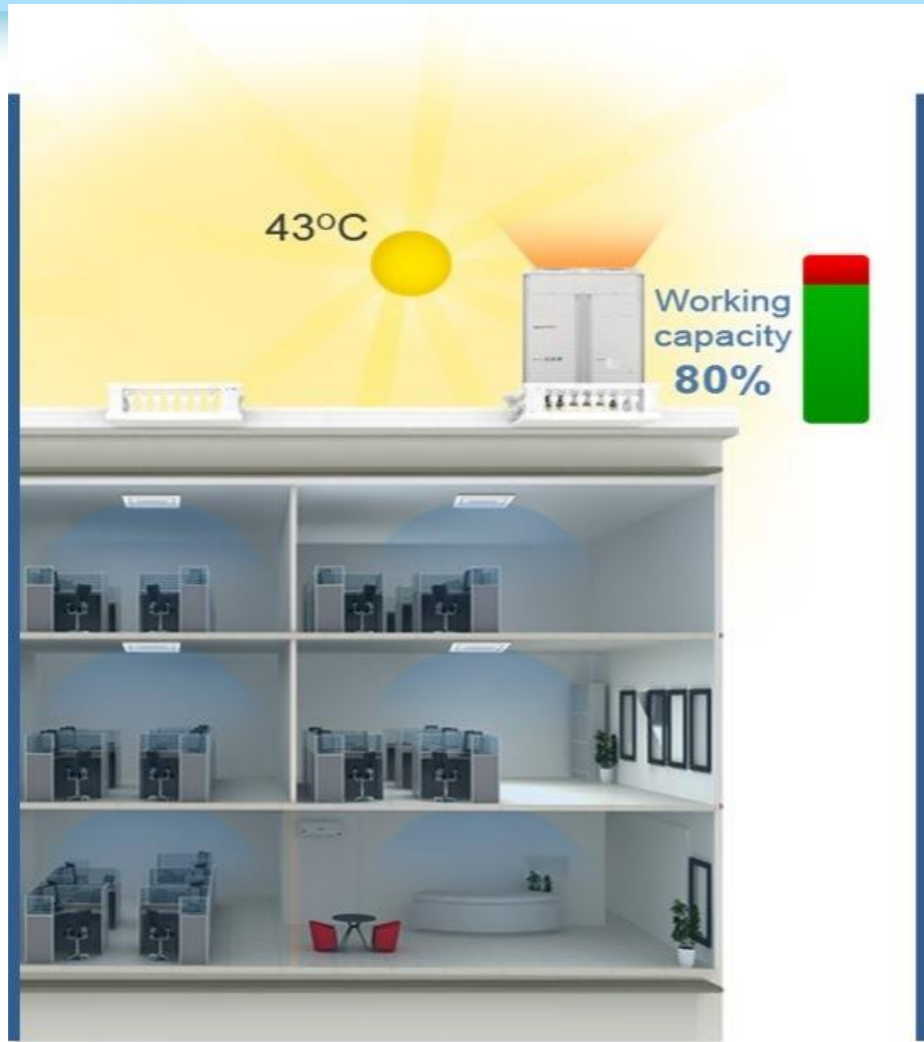

REGULAR VRF

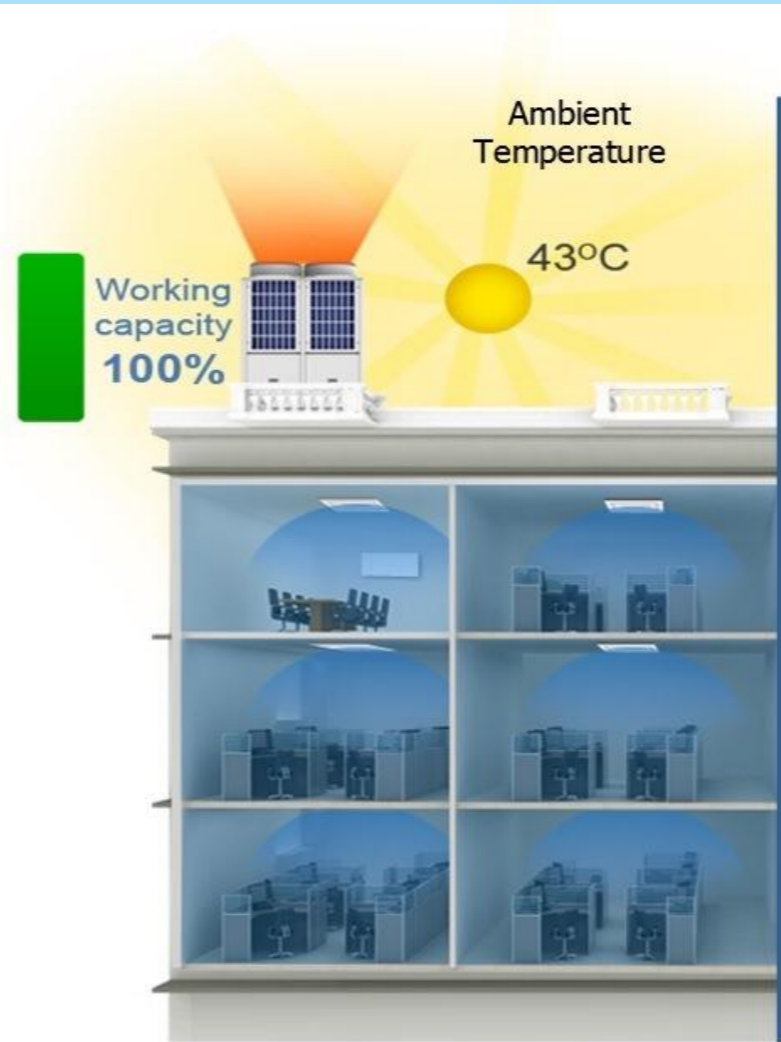

VRF V PLUS

Actual Capacity at 43°C



High Ambient Performance



- Actual capacity at 43°C
- No compressor unloading till 48°C
- Non-stop cooling at 56°C

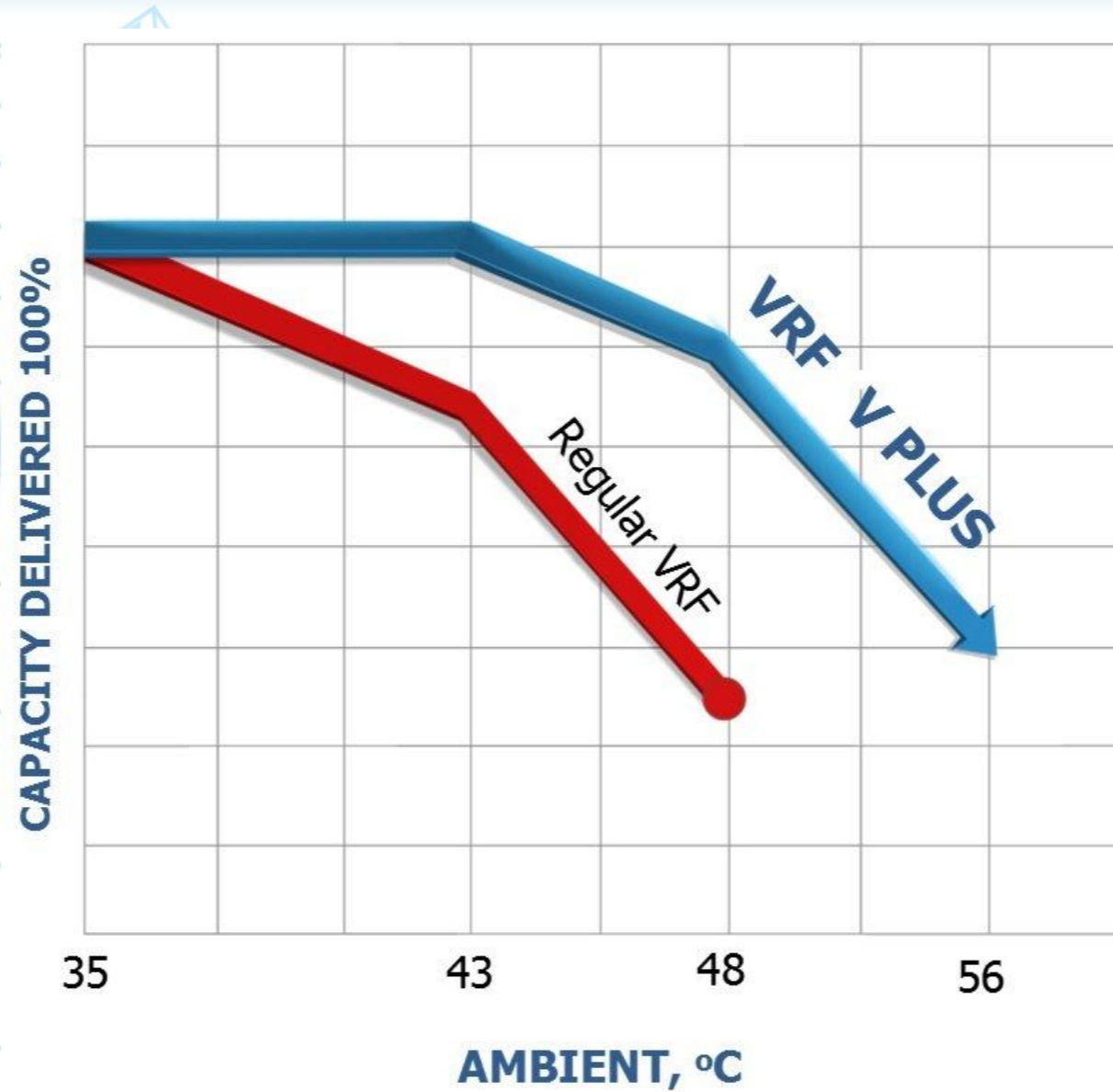

VRF V^{PLUS}
100% INVERTER



Best in Efficiency



BLUE STAR

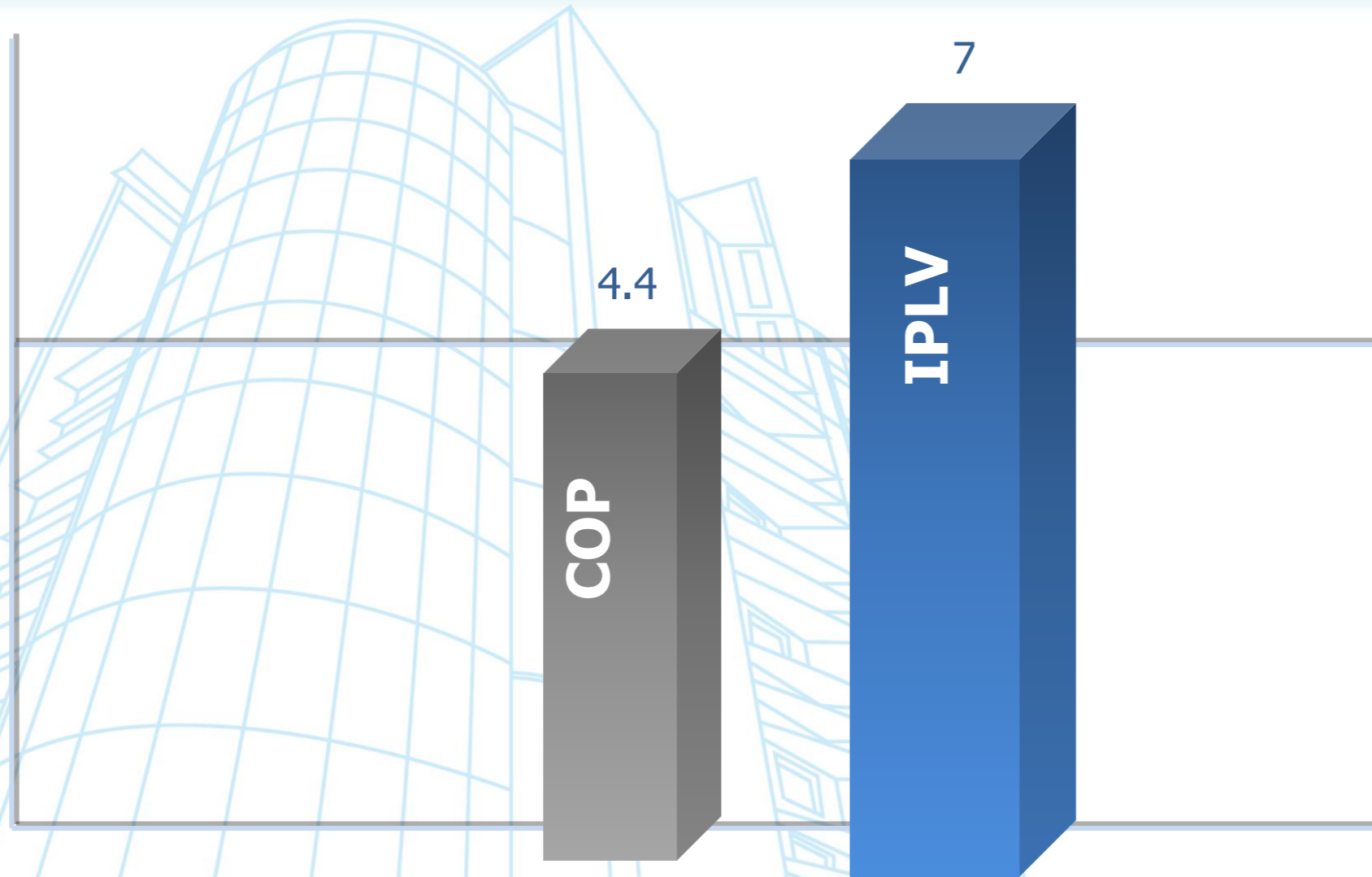

VRF V^{PLUS}
100% INVERTER

Extreme Load Handling Capacity



BLUE STAR

- 34 litre Accumulator for ODU
- Capable of handling diverse load conditions
- Can handle long piping distances



**Highest
in the
Industry**



VRF V^{PLUS}
100% INVERTER

Widest Operating Voltage Range



▼ Limited Operating Voltage Range

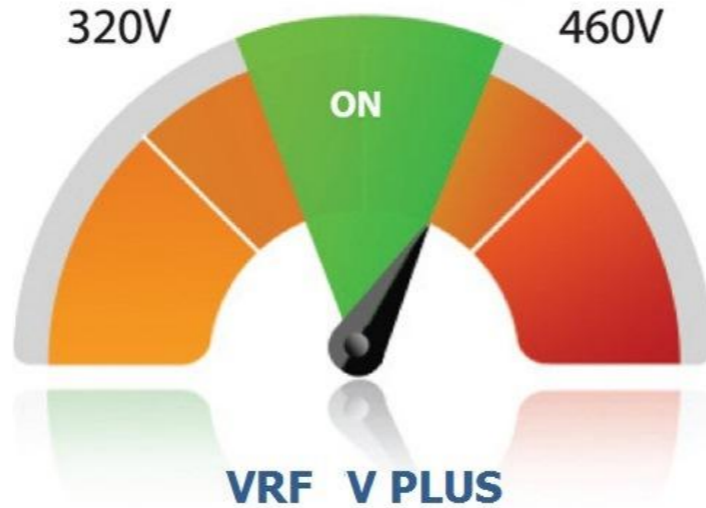

▼ Superior Operating Voltage Range

**Superior
Operating
Voltage Range:
320 to 460 V**



VRF V^{PLUS}
100% INVERTER

Longer Piping Distances



Dim	Length		Cool	Heat
	H1	Elevation between ODU and IDU	ODU above IDU	90 m
ODU below IDU			40 m	
H2	Elevation between IDU		40 m	15 m
H3	Elevation between ODU		5 m	
ML	Longest pipe length (Distance to first branch)		110 m	
L1	Farthest length between ODU and IDU		180 m	
L2	Farthest length from first branch to farthest IDU		90 m	
L3	Distance between ODUs		10 m	
Total piping length (Sum of liquid piping)			1000 m	

AHU Compatibility

- Unique feature allows coupling of Air Handling Units (AHUs) to VRF V Plus
- Up to 32 TR AHUs can be connected



AHU Kit

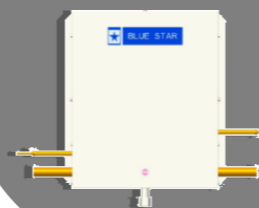

**Special Applications
can be catered to by
VRFs**

Mobile App

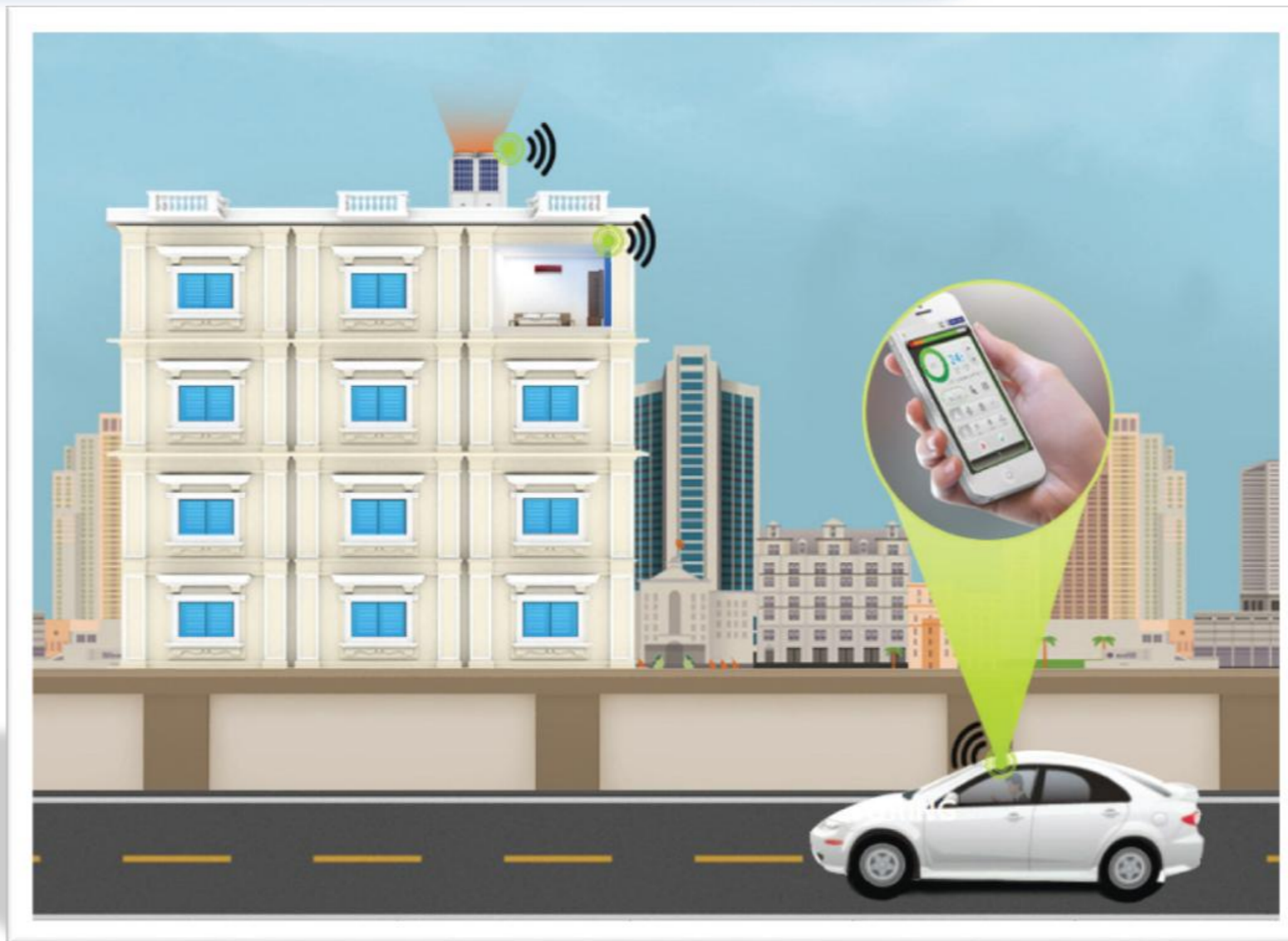

Widest Range of Products



BLUE STAR



Water Cooled Centrifugal Chillers



Turbocor Chillers



Packaged ACs & Ducted Splits



VRF V Plus



VRF Sprint



Water Cooled Screw Chillers with VFD



Water Cooled Screw Chillers



Air Cooled Screw Chillers



Water Cooled Scroll Chillers



Air Cooled Scroll Chillers



Process Chillers



Condensing Units

MAKE IN INDIA



MADE FOR INDIA



BLUE STAR

